

Exchange <sup>May</sup> 1975  
Chicago

CP-V D00 RELEASE

- MULTIPROCESSING
- FECP
- CP-V "PLUS" FEATURES

## CP-V MULTIPROCESSING

- o Design History
- o Hardware Requirements
- o Operations
- o MP in Action
- o Performance

## CP-V MULTI-PROCESSING

- o NO PROGRAM CONVERSION
- o NO CHANGE FOR USERS
- o TIGHTLY COUPLED
- o PRIMARY AND 1,2, OR 3 SECONDARY CPU's
- o IMPROVED AVAILABILITY
- o IMPROVED PRICE/PERFORMANCE
- o IMPROVED THROUGHPUT

## MULTIPROCESSING DESIGN HISTORY

- o Why Multiprocessing
- o Implementation Choices
- o Some data
- o More data and models

# Functional Monoprocessor CPU Utilization

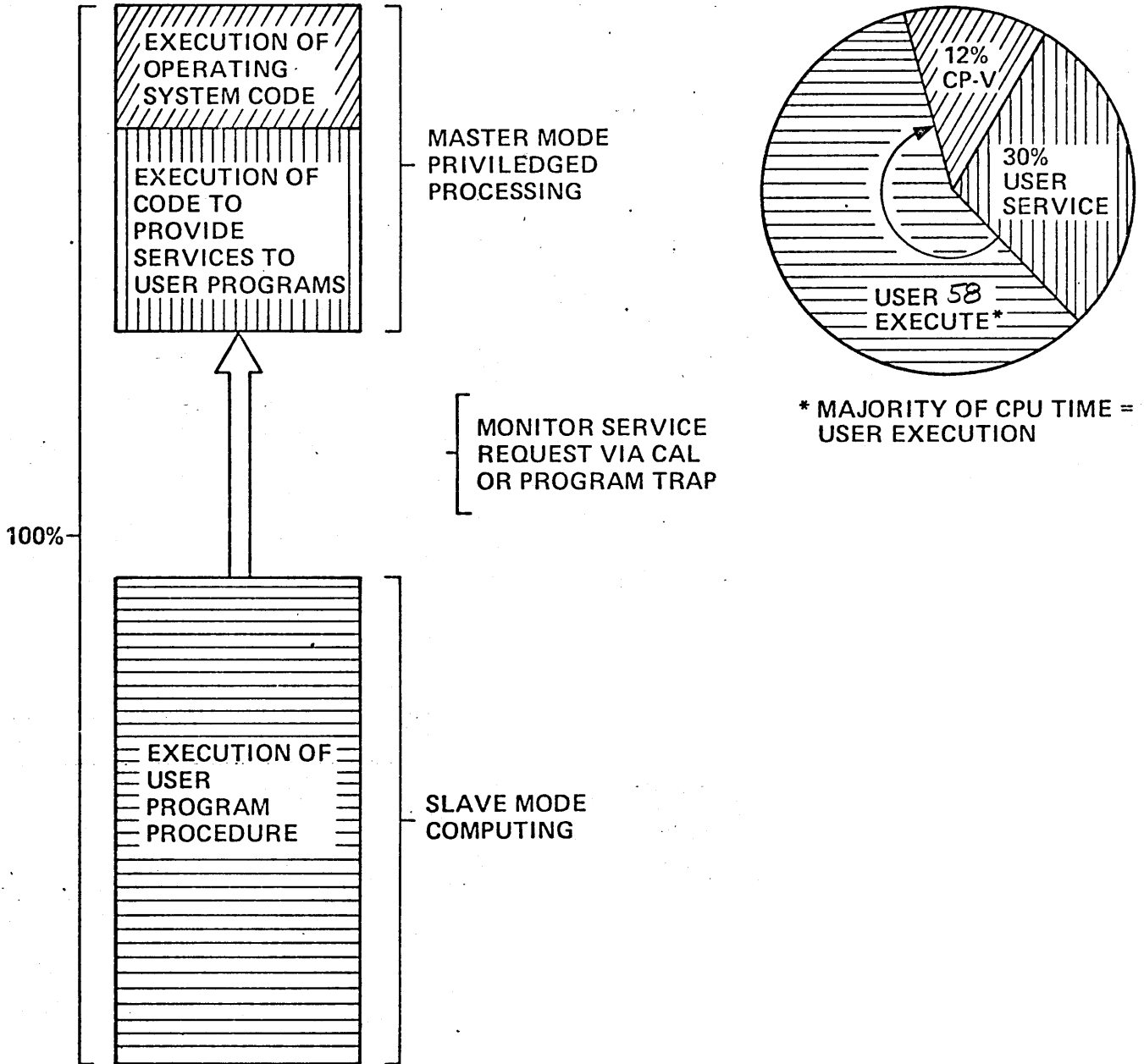

# CP-V CAL Processing Typical Distribution

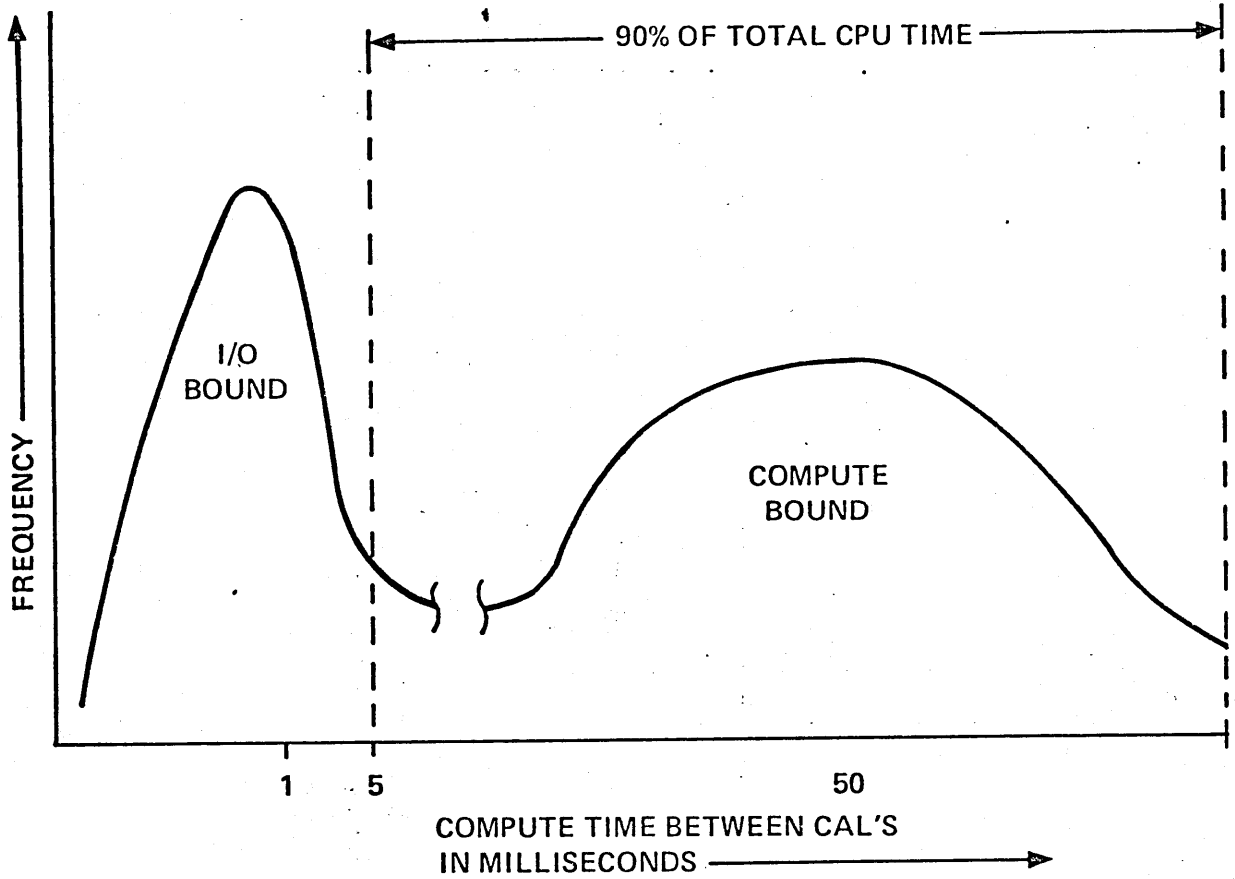

# Sigma 9 MP Configuration

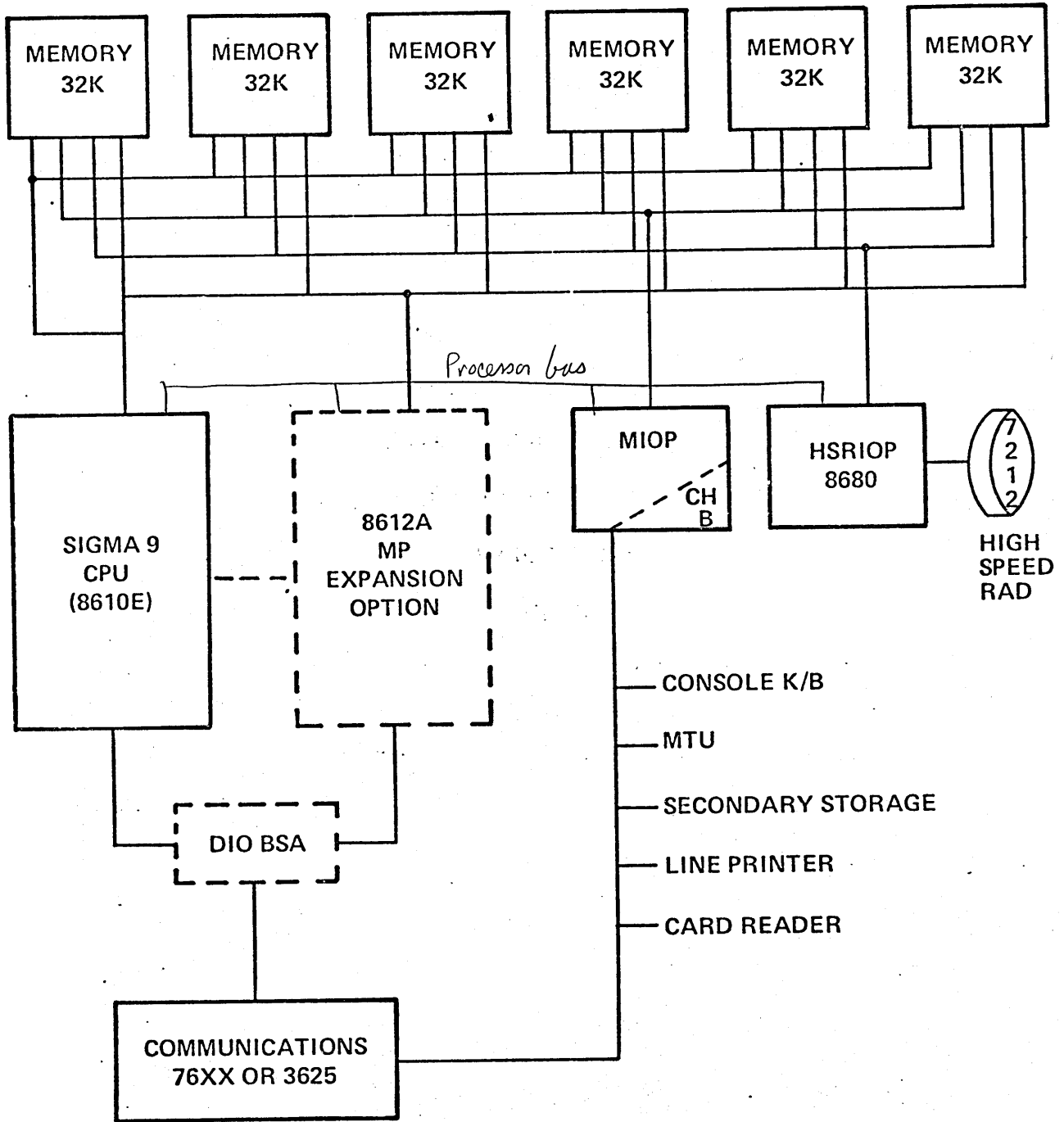

## CP-V MP IN ACTION

- INITIALIZATION AND RECOVERY
- OPERATOR REQUIREMENTS
- PROCESSORS COMMUNICATE VIA MEMORY
- SCHEDULER FLOW
- PERFORMANCE CONTROL



## CP-V MULTIPROCESSING PERFORMANCE

- o Benefits
- o Relative Performance
- o Primary Secondary Utilization
- o Recent Performance Data

PRIMARY  
PROCESSOR

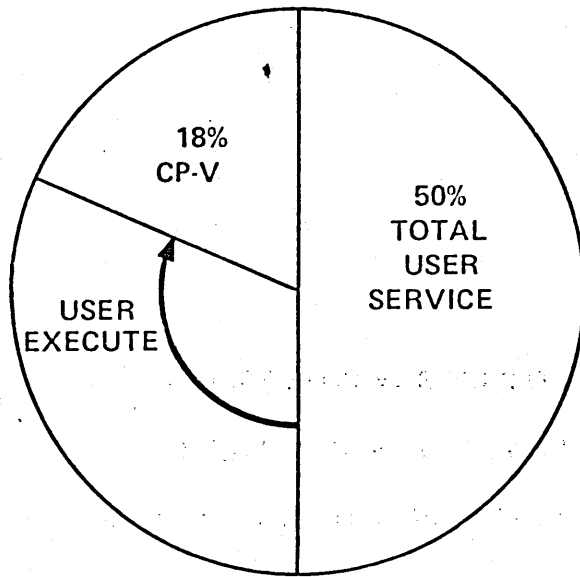

SECONDARY  
PROCESSOR

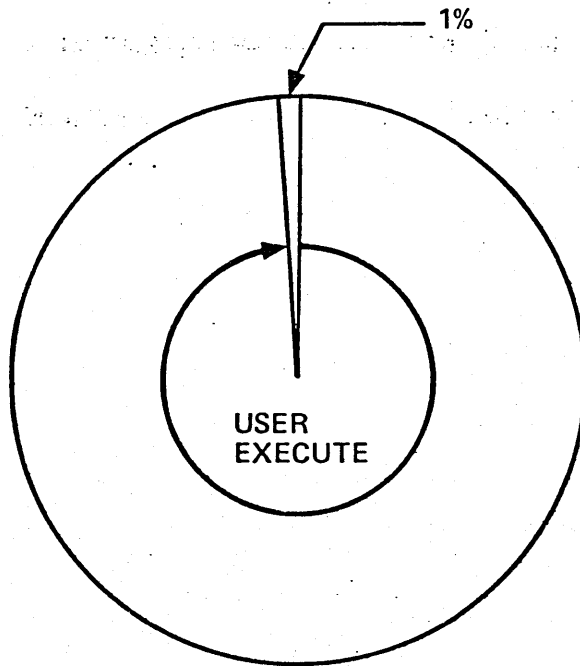

MP PERFORMANCE

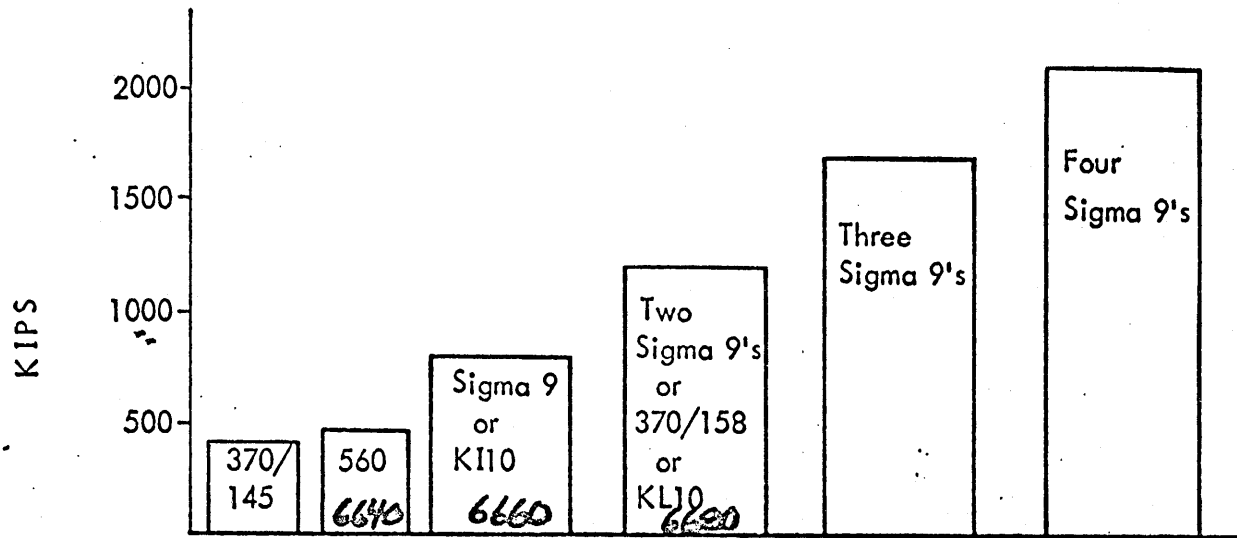

## PERFORMANCE GAIN

#CPUs	Thruput	Hardware Capacity	Percentage of Capacity
1	1.00	1.00	100
2	1.75	1.82	96
3	2.42	2.55	95
4	3.00	3.15	95

STATISTICS ON-LINE

INTERVAL FROM 10:32 TO 10:46 OCT 31, '75

MINS SINCE STARTUP = 335  
 NUMBER OF USERS = 53  
 NUMBER OF ONLINE = 40  
 NUMBER OF BATCH = 6  
 NUMBER OF GHOSTS = 7  
 90% RESPONSE TIME = 500

CPU %	ALL	SNAP	I/O PER MIN	ALL	SNAP
BATCH EXEC	63.9	63.3	SERVICE REQ	8674	12585
BATCH SERV	11.7	5.4	INTERACTIONS	22	113
ONLINE EXEC	8.8	21.7	CHAR IN	544	5766
ONLINE SERV	6.0	23.9	CHAR OUT	1730	5458
GHOST EXEC	.4	.6	TERM WRITES	82	266
GHOST SERV	.1	.1	I/O ACCESSES	1759	3343
MONITOR SERV	11.4	29.3	# TRUNCES	7	17
IDLE	25.6	.0	AIR ATTEMPTS	85	82
SWAP WAIT	.1	.1	AIR HITS	34	25
I/O WAIT	6.9	1.4	SYMBIONT	71	121
I/O&SWP WAIT	1.1	5.2	IN SWAPS	58	256
TOTAL	135.8	151.0	OUT SWAPS	42	181

SCPU USE %	ALL	SNAP	EVENT RATE/MIN	ALL	SNAP
SCPU #1 EXEC	36.0	52.6	MASTER CALS	7066	9745
SCPU #1 IDLE	35.8	45.4	SCPU #1 CALS	1607	2840
SCPU #1 TOT	71.8	98.0	MASTER SCHEDS	3474	6702
			SCPU #1 SCHEDS	1790	3173

## MULTI-PROCESSING

WE SAY MASTER/SLAVE BUT HERE  
ARE CP-V's ANONYMOUS FEATURES

- EACH ADDED CPU IS A COMPUTE PERIPHERAL
- ONE JOB IS USUALLY WORKED ON BY SEVERAL CPU's IN THE COURSE OF ITS EXECUTION
- ANY CPU CAN BE MASTER
- MASTERS MAY BE CHANGED DYNAMICALLY
- SINGLE COPY OF THE SYSTEM
- CPU's CAN BE DYNAMICALLY PARTITIONED OUT
- ALL PERIPHERALS & FILES ARE AVAILABLE TO ALL JOBS

CP-V "PLUS" AND OTHER D00 FEATURES

- REMOTE PROCESSING
- TIME SHARING TERMINAL
- LOADER
- FILE MANAGEMENT
- MISCELLANEOUS ENHANCEMENTS

REMOTE PROCESSING

- IBM 2780 ERROR RECOVERY
- IBM 3780 SUPPORT
- CP-V TO CP-V FILE TRANSMISSION:  
ISCL/RATLER



TIME SHARING TERMINAL FEATURES - I

- AUTOSAVE ON HANGUP
- TERMINAL COUPLING
- OUTPUT "HOLD", "IGNORE" MODES
- EASIER INSTALLATION OF TRANSLATION TABLES

TIME SHARING TERMINAL FEATURES - II

- HALF-DUPLEX LINE SUPPORT - 1200 BAUD
- READ TIMEOUT SPECIFICATION
- INPUT AND/OR OUTPUT DELETE SPECIFICATION
- READ CONDITIONAL ON EXISTING INPUT
- TERMINAL BLOCK/UNBLOCK IN SECONDS

## LOADER

- 2X TO 10X FASTER
- LIBRARY LOAD MODULES WITH DSECTS
- LYNX ON-LINE INTEREACE
- LEMUR LIBRARY MAINTENANCE
- ROM LOADING FROM LIBRARIES

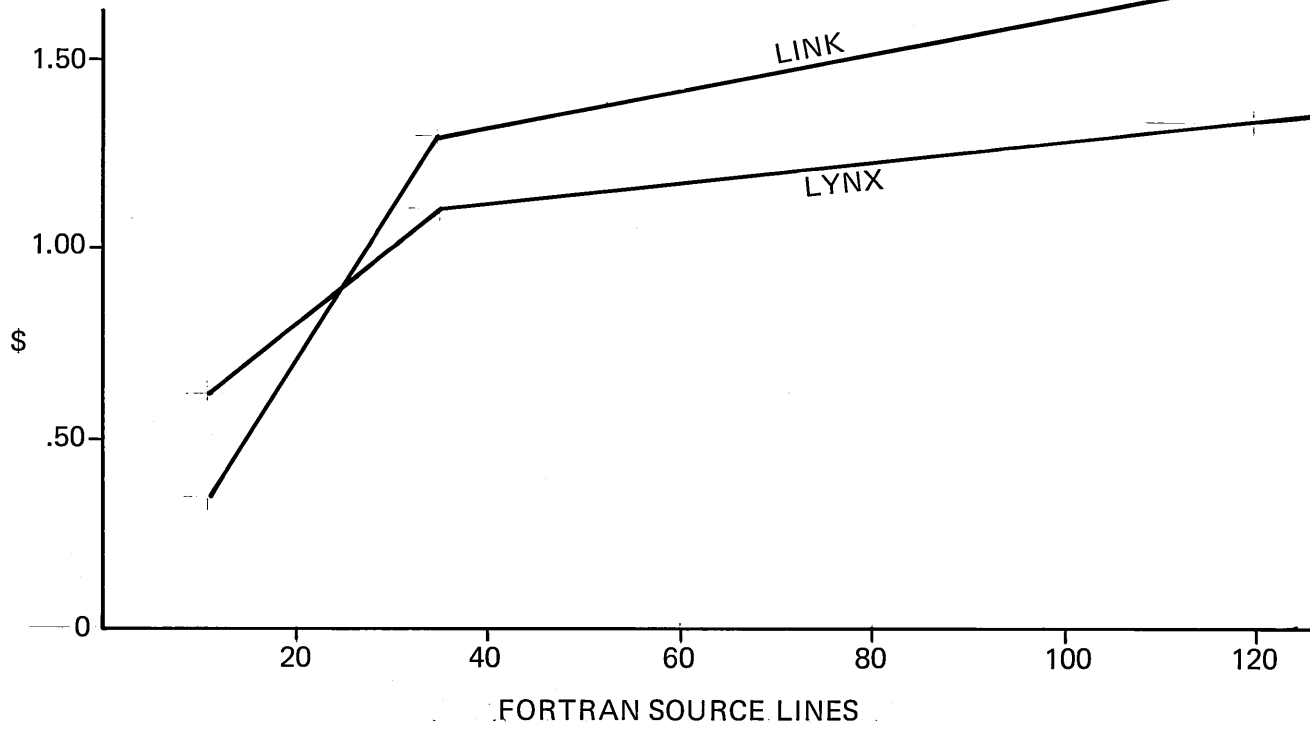

## FILE MANAGEMENT

- NAME AND ATTRIBUTE CHANGE AT CLOSE
- MULTIPLE UNDER NAMES FOR EXECUTE
- PRIVATE PACK REMOUNT AFTER RECOVERY
- HGP DUMP BY FIX
- REDUCED OVERHEAD FOR FILE OPENS

## MISCELLANEOUS USER ENHANCEMENTS

- LOAD AND LINK
- NORMAL MODE FOR FORTRAN DEBUG
- REAL TIME M:CAL AND COUNTER ZERO
- DELTA ASSOCIATION AFTER ABORT
- DELTA BREAKPOINTS AT OVERLAY CHANGE

## MISCELLANEOUS SYSTEM ENHANCEMENTS

- KEYIN TO CHANGE EXECUTION PRIORITY
- OPERATOR BROADCAST-IMMEDIATE MESSAGE
- ON-LINE VOLINIT
- PRIVILEGED PROCESSORS
- CONCURRENT SYMBIONT OUTPUT
- GENMD ENHANCEMENTS

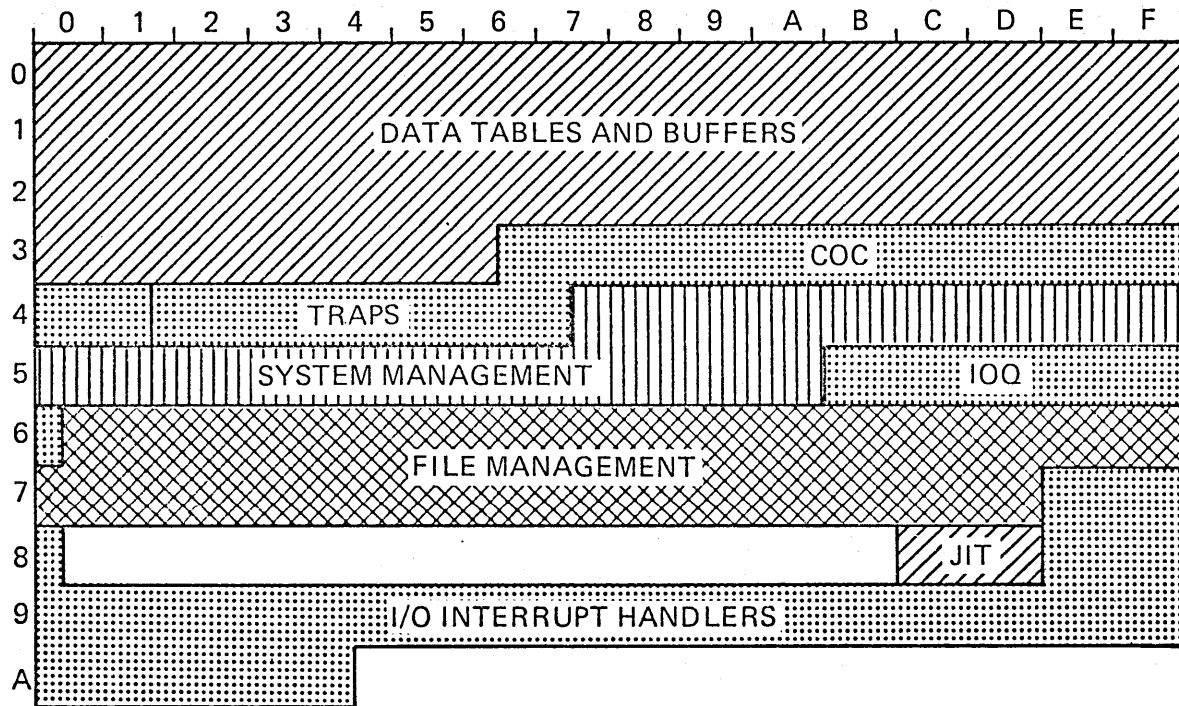

CP-V REAL MEMORY MAP



THE CP-V ZOO

- FROG
- LEMUR
- LYNX
- MOOSE
- OX
- PIGEON
- RATLER

## MULTI-PROCESSING

- TIGHTLY COUPLED
- NO CHANGE FOR USERS
- PRIMARY/SECONDARY CPU's
- IMPROVED AVAILABILITY
- IMPROVED PERFORMANCE
- ADD ONE, TWO, OR THREE CPU's

MP PERFORMANCE

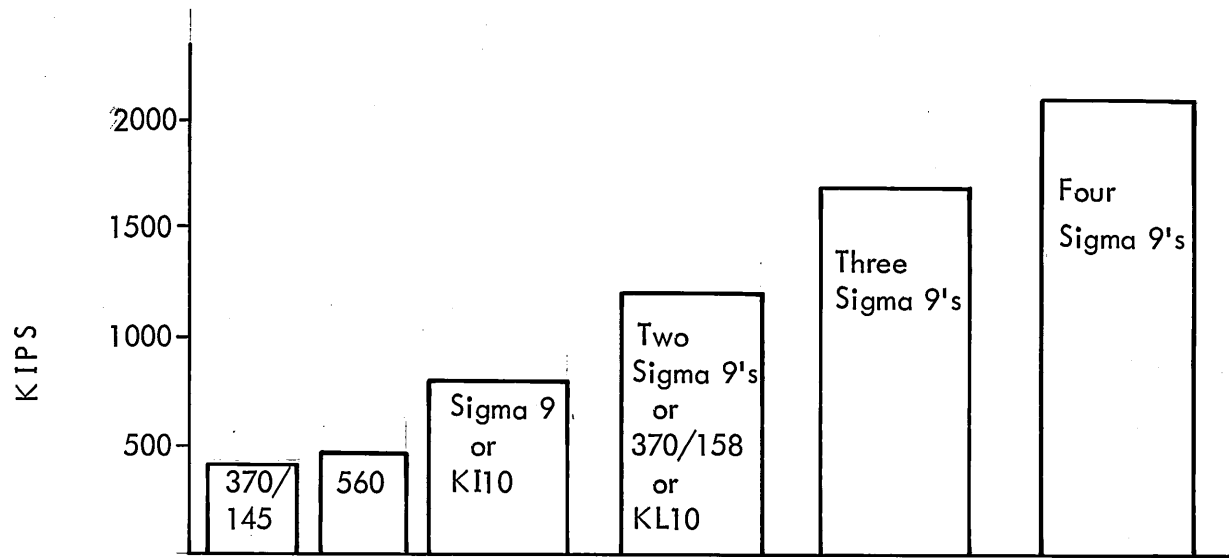

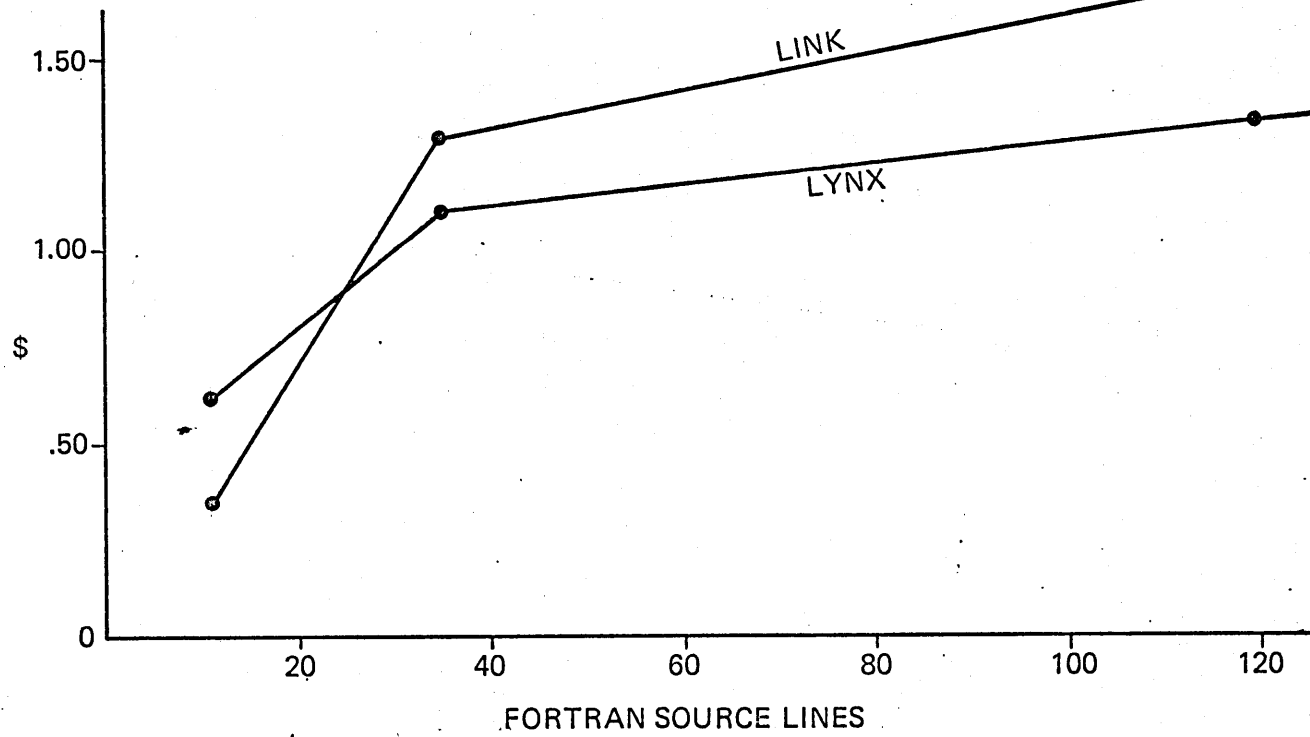

THESE SLIDES ARE FROM A PRESENTATION ON CP-V VERSION D00,  
MULTIPROCESSING AND "PLUS" FEATURES.

PRESENTED DECEMBER 3rd AT THE SAN DIEGO MEETING OF  
EXCHANGE, THE XEROX COMPUTER USERS GROUP.

G.E. BRYAN

December 1975

**CP-V**

## **CP-V D00 RELEASE**

- **MULTIPROCESSING**
- **FECF**
- **CP-V "PLUS" FEATURES**

# **Multiprocessing**

- **GENERAL CHARACTERISTICS**
- **DESIGN HISTORY**
- **MP IN ACTION**
- **PERFORMANCE**



# **Multiprocessing**

## **GENERAL CHARACTERISTICS**

- **TIGHTLY COUPLED**
- **PRIMARY AND 1, 2, OR 3 SECONDARY CPU'S**
- **NO PROGRAM CONVERSION**
- **NO CHANGE FOR USERS**
- **IMPROVED AVAILABILITY**
- **IMPROVED PRICE/PERFORMANCE**
- **IMPROVED THROUGHPUT**

# Multiprocessing

## SIGMA 9 MP CONFIGURATION

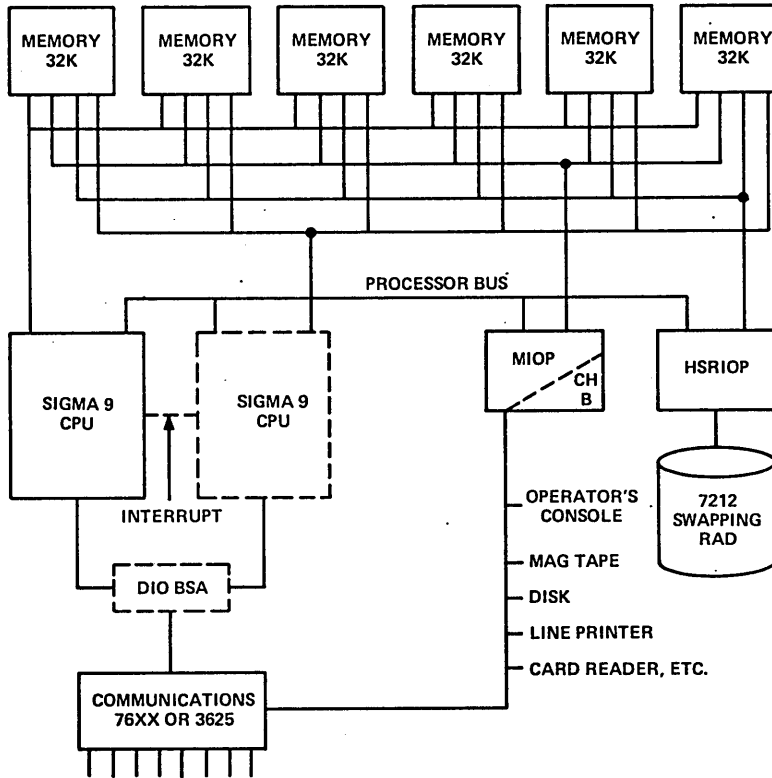

# Multiprocessing

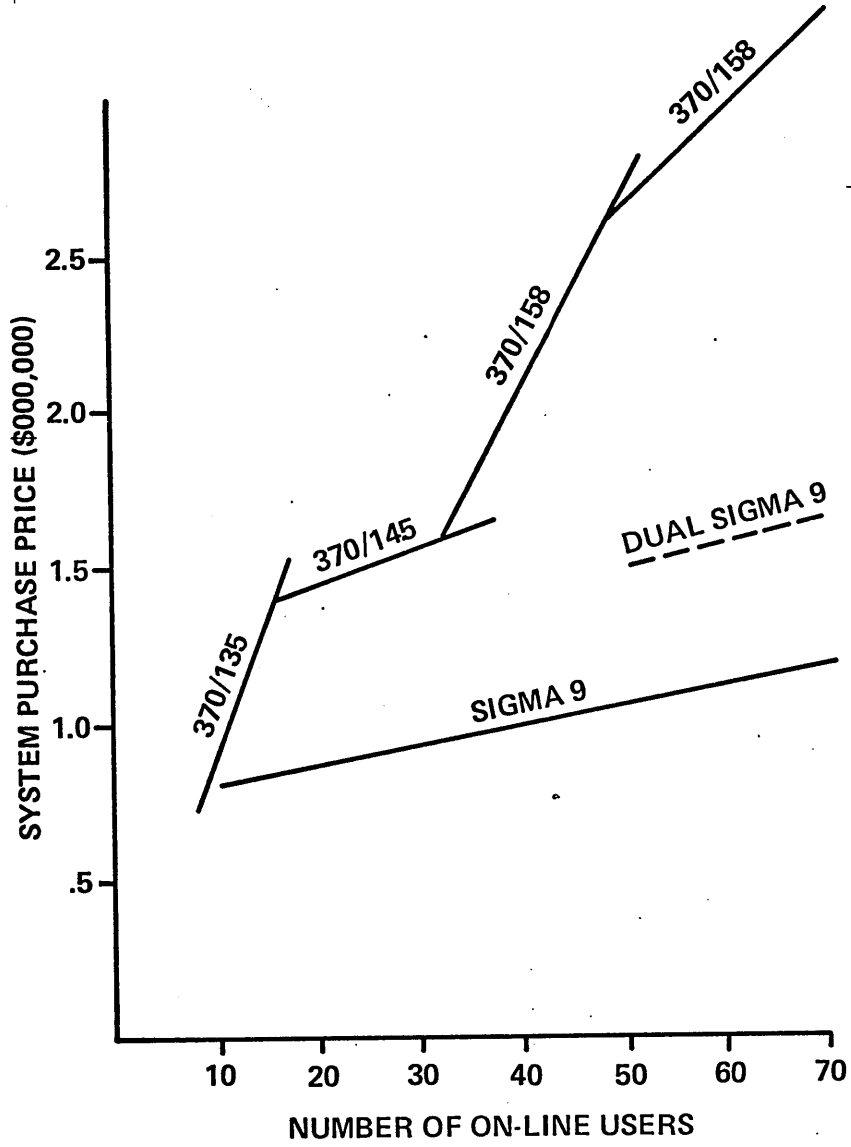

# **Multiprocessing**

## **MULTIPROCESSING DESIGN HISTORY**

- **WHY MULTIPROCESSING**
- **IMPLEMENTATION CHOICES**
- **SOME DATA**
- **MORE DATA AND MODELS**

# Multiprocessing

## DUAL REDUNDANT SYSTEMS

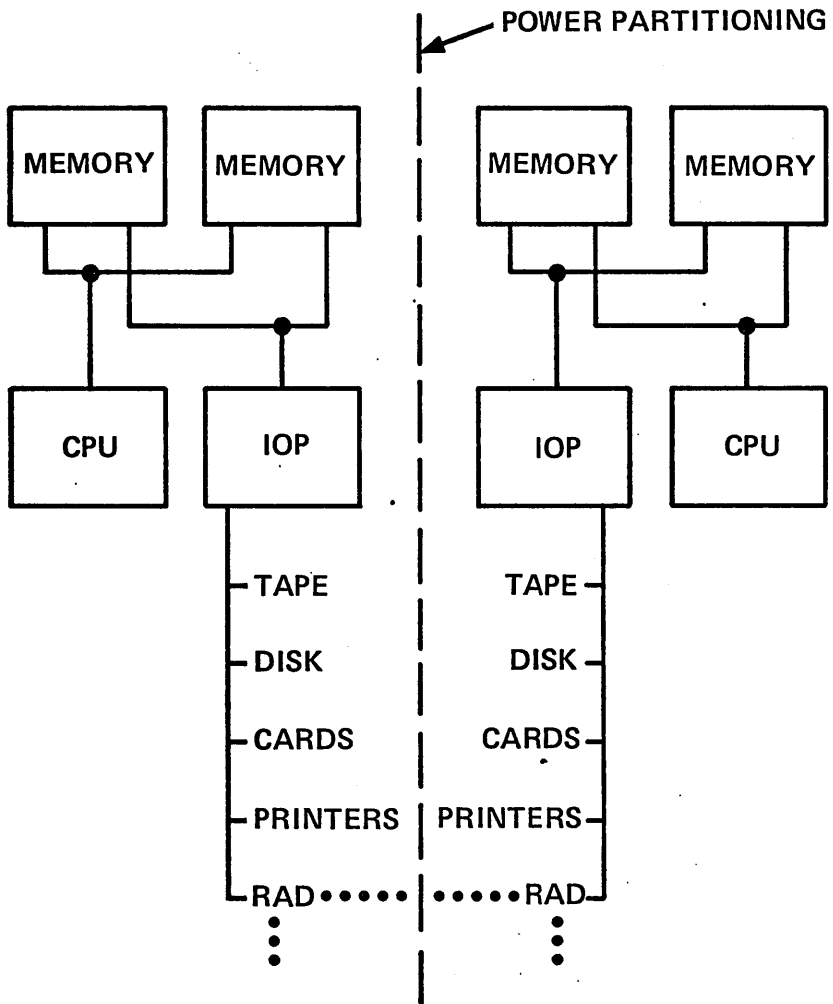

# Multiprocessing

## LOOSELY COUPLED SYSTEMS

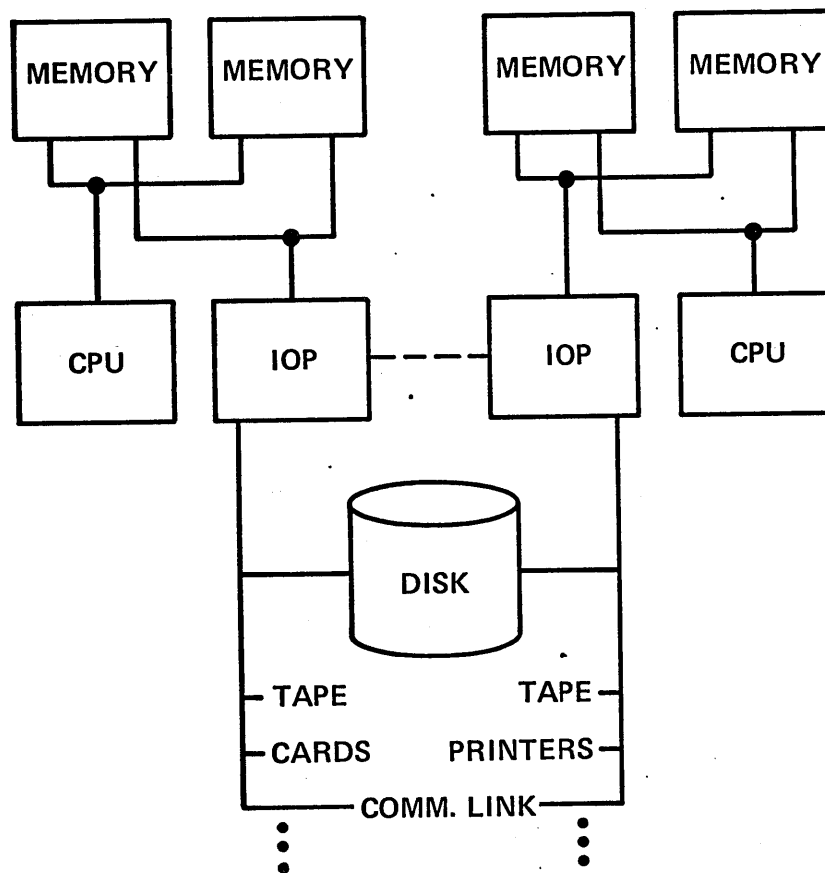

# Multiprocessing

## TIGHTLY COUPLED SYSTEMS

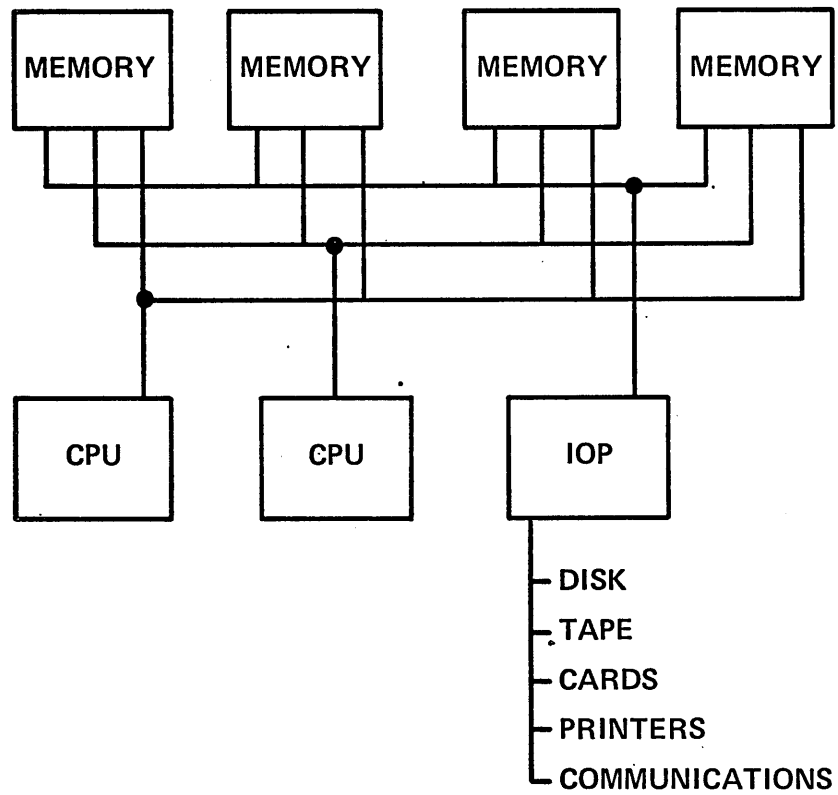

# MONOPROCESSOR CPU UTILIZATION

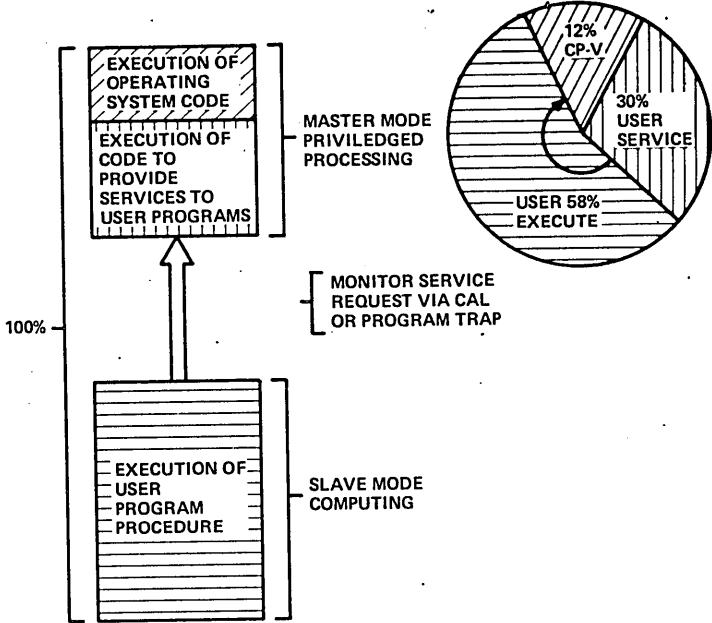



# Multiprocessing

CP-V CAL PROCESSING DISTRIBUTION

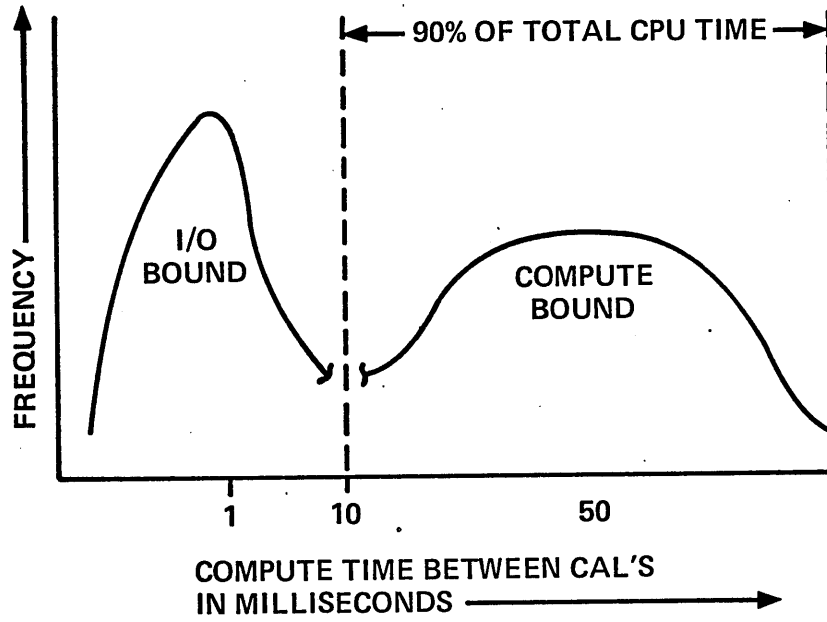

# **Multiprocessing**

## **CP-V MP IN ACTION**

- **INITIALIZATION AND RECOVERY**
- **OPERATOR REQUIREMENTS**
- **PROCESSORS COMMUNICATE VIA MEMORY**
- **SCHEDULER FLOW**
- **PERFORMANCE CONTROL**

# **Multiprocessing**

## **INITIALIZATION AND RECOVERY**

- **MASTER IS FIRST CPU TO START**
- **BOOT IDENTICAL TO MONO PROCESSING**
- **MOOSE GHOST INITIALIZES SLAVE CPU'S**
- **MASTER OR SLAVE REQUESTS RECOVERY**
- **MASTER PERFORMS AUTOMATIC RECOVERY**
- **OPERATOR SELECTS MASTER**

# Multiprocessing

CP-V MP IN ACTION

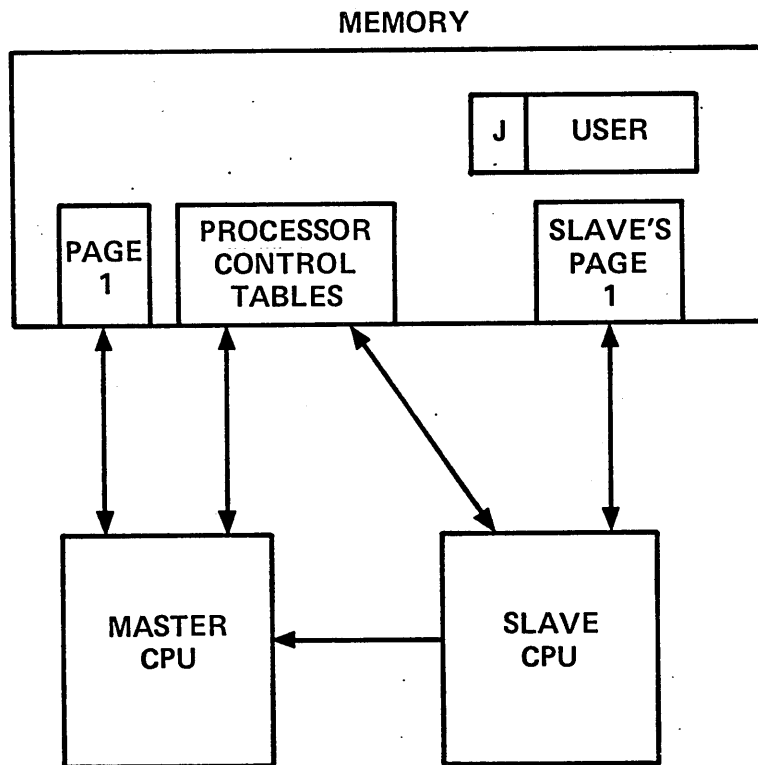

# Multiprocessing

CP-V MP SCHEDULING

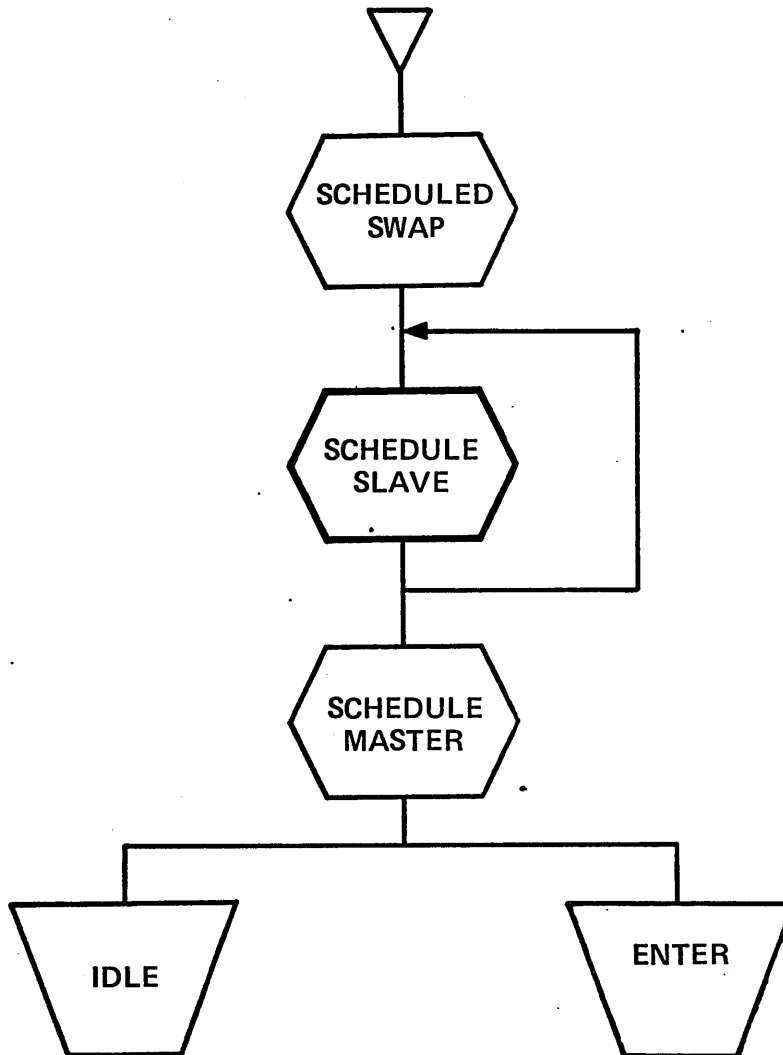

# Multiprocessing

## MULTIPROCESSING AND SHARED PROGRAMS

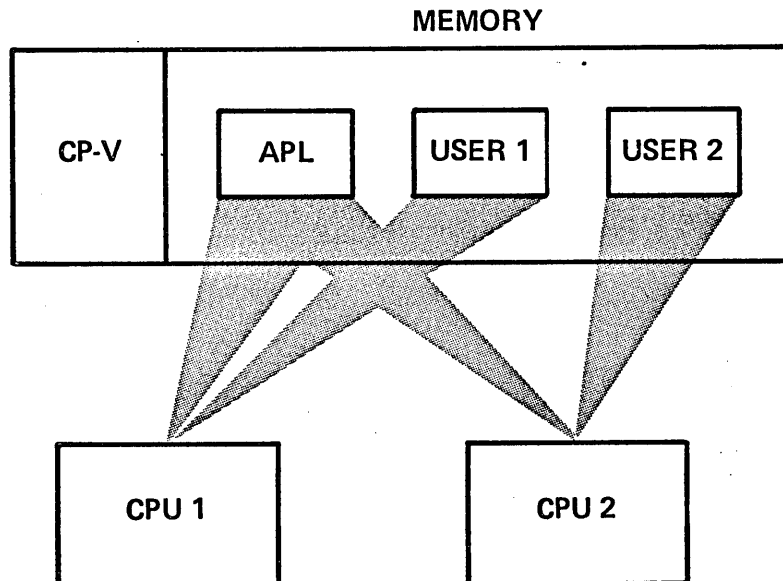

# **Multiprocessing**

## **MP PERFORMANCE CONTROL**

- **MINIMUM SLAVE QUANTUM – 200 MSEC**
- **MAXIMUM SLAVE QUANTUM – 5000 MSEC**
- **MS/CAL THRESHOLD – 0**

# **Multiprocessing**

## **CP-V MULTIPROCESSING PERFORMANCE**

- **RELATIVE PERFORMANCE**
- **PRIMARY SECONDARY UTILIZATION**
- **RECENT PERFORMANCE DATA**



# Multiprocessing

## MP PERFORMANCE

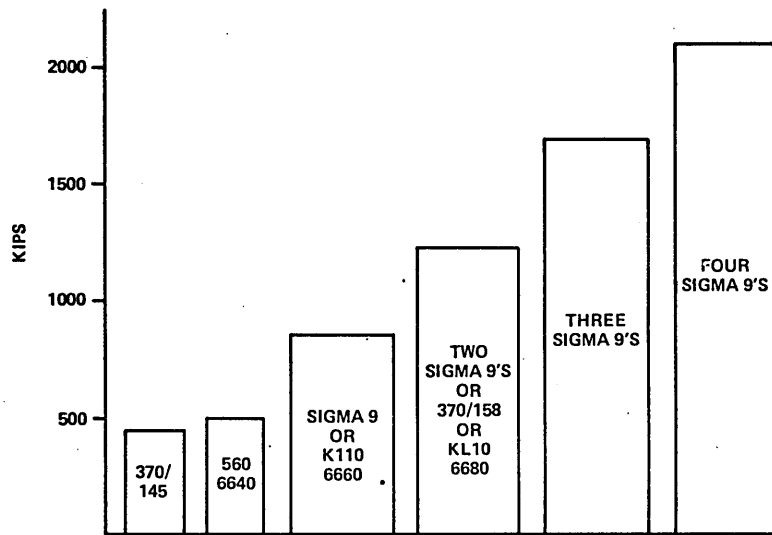

# Multiprocessing

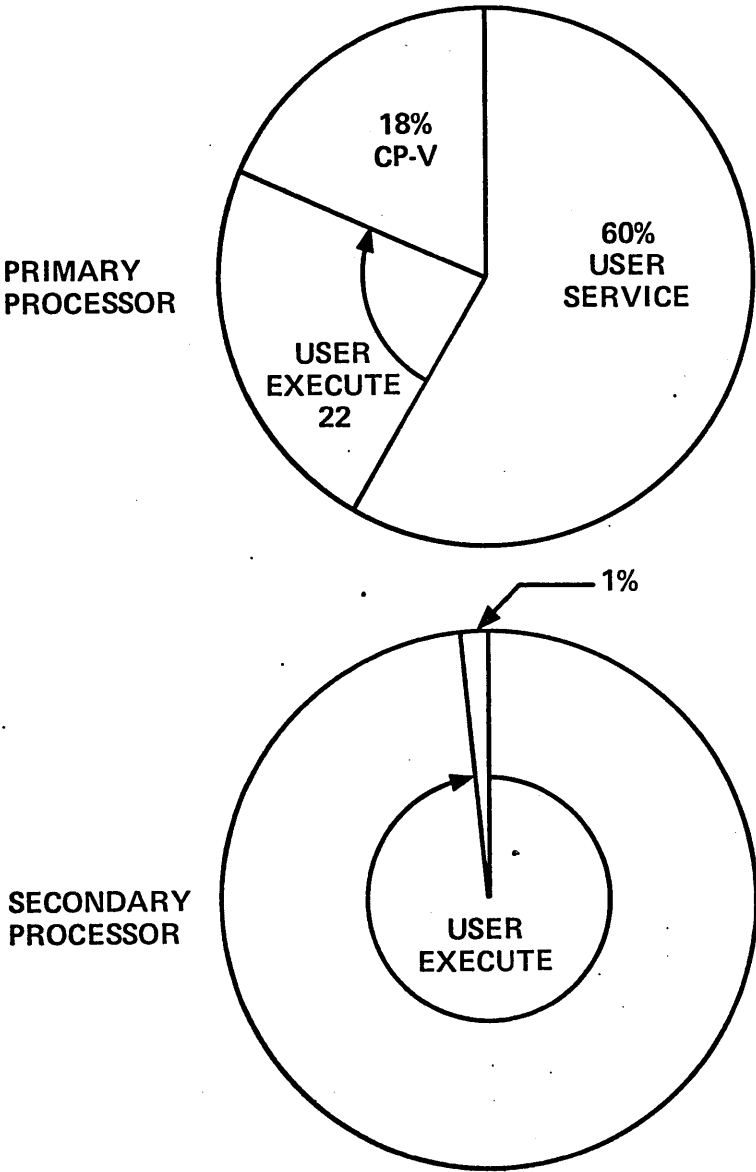

# Multiprocessing

## PERFORMANCE AGAINST CAPACITY

#CPUs	CP-V THRUPUT	HARDWARE CAPACITY	PERCENTAGE OF CAPACITY
1	1.00	1.00	100
2	1.75	1.82	96
3	2.42	2.55	95
4	3.00	3.15	95

# Multiprocessing

## STATISTICS ON-LINE

INTERVAL FROM 10:25 TO 10:40 OCT 20, '75

MINS SINCE STARTUP= 590

NUMBER OF USERS = 49

NUMBER OF ON-LINE = 38

NUMBER OF BATCH = 5

NUMBER OF GHOSTS = 6

90% RESPONSE TIME = 350

CPU %	ALL	SNAP	I/O PER MIN	ALL	SNAP
BATCH EXEC	16.7	41.1	SERVICE REQ	7268	10458
BATCH SERV	15.6	7.5	INTERACTIONS	8	56
ONLINE EXEC	7.0	65.1	CHAR IN	141	804
ONLINE SERV	2.0	17.0	CHAR OUT	1126	6589
GHOST EXEC	.9	.3	TERM WRITES	48	250
GHOST SERV	.0	.0	I/O ADDRESSES	1628	2299
MONITOR SERV	3.9	17.2	# TRUNCS	2	28
IDLE	38.5	2.2	AIR ATTEMPTS	229	96
SWAP WAIT	.5	.1	AIR HITS	42	31
I/O WAIT	22.4	5.4	SYMBIONT	40	185
I/O&SWP WAIT	.7	.5	IN SWAPS	17	84
TOTAL	102.2	176.4	OUT SWAPS	14	63

SCPU USE %	ALL	SNAP	EVENT RATE/MIN	ALL	SNAP
SCPU #1 EXEC	8.2	76.4	MASTER CALS	7061	9484
SCPU #1 IDLE	19.9	23.0	SCPU #1 CALS	207	974
SCPU #1 TOT	28.1	99.4	MASTER SCHEDS	911	4267
			SCPU #1 SCHEDS	227	1181

CP-V D00 DUAL SIGMA 9 256K

# **Multiprocessing**

- **EACH ADDED CPU IS A COMPUTE PERIPHERAL**
- **ONE JOB IS USUALLY WORKED ON BY SEVERAL CPU'S IN THE COURSE OF ITS EXECUTION**
- **ANY CPU CAN BE MASTER**
- **MASTERS MAY BE CHANGED**
- **SINGLE COPY OF THE CP-V SYSTEM**
- **CPU'S CAN BE DYNAMICALLY PARTITIONED OUT**
- **ALL PERIPHERALS & FILES ARE AVAILABLE TO ALL JOBS**

# **CP-V D00**

## **CP-V "PLUS" AND OTHER D00 FEATURES**

- **REMOTE PROCESSING**
- **TIME SHARING TERMINAL**
- **TRANSACTION PROCESSING**
- **LOADER**
- **FILE MANAGEMENT**
- **MISCELLANEOUS ENHANCEMENTS**

# **CP-V D00**

## **REMOTE PROCESSING**

- **IBM 2780 ERROR RECOVERY**
- **IBM 3780 SUPPORT**
- **CP-V TO CP-V FILE TRANSMISSION:**

**ISCL/RATLER**

# CP-V D00

## TIME SHARING TERMINAL FEATURES – I

- AUTOSAVE ON HANGUP
- TERMINAL COUPLING
- OUTPUT "HOLD", "IGNORE" MODES
- PAGE ERASE SEQUENCES FOR TEKTRONICS AND TTY 40
- TERMINAL COMMANDS ON FILE -OX



# **CP-V D00**

## **TIME SHARING TERMINAL FEATURES – II**

- **HALF-DUPLEX LINE SUPPORT – 1200 BAUD**
- **READ TIMEOUT SPECIFICATION**
- **INPUT AND/OR OUTPUT DELETE SPECIFICATION**
- **READ CONDITIONAL ON EXISTING INPUT**
- **TERMINAL BLOCK/UNBLOCK IN SECONDS**

# **CP-V D00**

## **TRANSACTION PROCESSING**

- **TP/TS SWITCHING OF TERMINALS**
- **ADDITIONAL CONTROL**
- **IMPROVED ERROR ANALYSIS**
- **IMPROVED REFERENCE MANUAL**

# **CP-V D00**

## **LOADER**

- **2X TO 10X FASTER**
- **LIBRARY LOAD MODULES WITH DSECTS**
- **LYNX ON-LINE INTERFACE**
- **LEMUR LIBRARY MAINTENANCE**
- **ROM LOADING FROM LIBRARIES**

# CP-V D00

LOADER SPEED

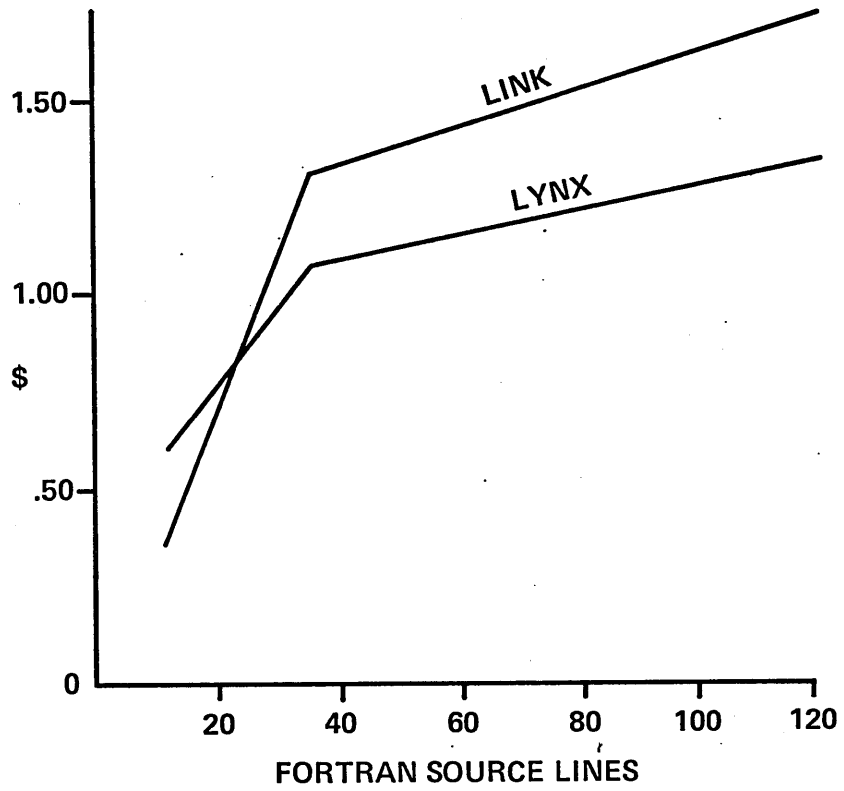

# **CP-V D00**

## **FILE MANAGEMENT**

- **NAME AND ATTRIBUTE CHANGE AT CLOSE**
- **MULTIPLE 'UNDER' NAMES FOR EXECUTE**
- **PRIVATE PACK REMOUNT AFTER RECOVERY**
- **HGP DUMP BY FIX**
- **FASTER FILE OPENS VIA CFU SEARCH**

# **CP-V D00**

## **MISCELLANEOUS USER ENHANCEMENTS**

- **LOAD-AND-LINK**
- **NORMAL MODE FOR FORTRAN DEBUG**
- **REAL TIME M: CAL AND COUNTER ZERO**
- **DELTA ASSOCIATION AFTER ABORT**
- **DELTA BREAKPOINTS AT OVERLAY CHANGE**

# **CP-V D00**

## **MISCELLANEOUS SYSTEM ENHANCEMENTS**

- **KEYIN TO CHANGE EXECUTION PRIORITY**
- **OPERATOR BROADCAST—IMMEDIATE MESSAGE—PIGEON**
- **ON-LINE VOLINIT**
- **PRIVILEGED PROCESSORS**
- **CONCURRENT SYMBIONT OUTPUT**
- **GENMD ENHANCEMENTS**

# CP-V D00

## CP-V REAL MEMORY MAP

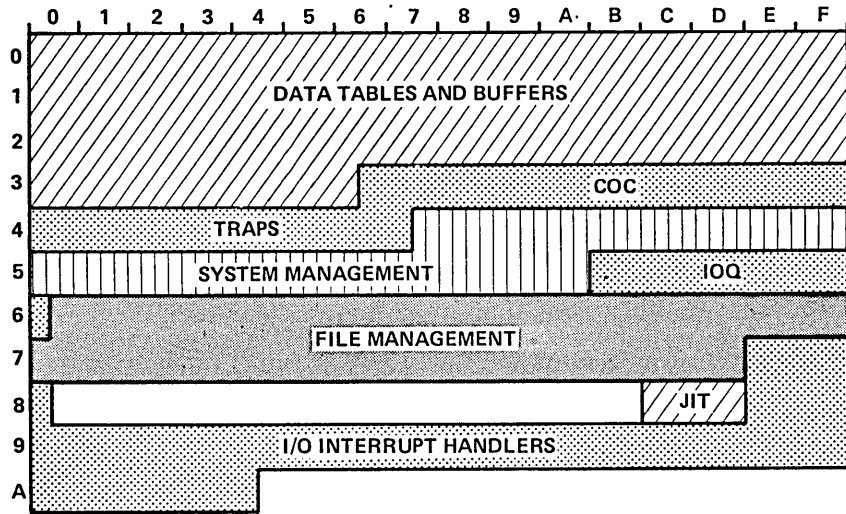

10A



# CP-V D00

## STATISTICS ON-LINE

INTERVAL FROM 10:38 TO 10:53 NOV 03, '75

MINS SINCE STARTUP = 457

NUMBER OF USERS = 43

NUMBER OF ONLINE = 32

NUMBER OF BATCH = 6

NUMBER OF GHOSTS = 5

90% RESPONSE TIME = 500

CPU %	ALL	SNAP	I/O PER MIN	ALL	SNAP
BATCH EXEC	31.3	117.0	SERVICE REQ	10483	8168
BATCH SERV	22.1	13.8	INTERACTIONS	11	41
ONLINE EXEC	18.3	19.9	CHAR IN	157	511
ONLINE SERV	2.5	9.6	CHAR OUT	1331	4845
GHOST EXEC	1.2	.4	TERM WRITES	51	202
GHOST SERV	.0	.0	I/O ACCESSES	2091	2297
MONITOR SERV	7.2	19.5	# TRUNCs	4	17
IDLE	22.2	.0	AIR ATTEMPTS	245	235
SWAP WAIT	.3	.0	AIR HITS	232	173
I/O WAIT	15.5	.3	SYMBIONT	72	314
I/O&SWP WAIT	1.0	.5	IN SWAPS	48	149
TOTAL	121.8	180.9	OUT SWAPS	38	110

EVENT RATE/MIN	ALL	SNAP	SCPU USE %	ALL	SNAP
MASTER CALS	10068	6050	SCPU #1 EXEC	23.4	80.9
SCPU #1 CALS	415	2118	SCPU #1 IDLE	23.7	17.5
MASTER SCHEDS	1524	5384	SCPU #1 TOT	47.1	98.4
SCPU #1 SCHEDS	479	2228			

RESOURCES IN USE	#	RAHD-AIR/MIN	ALL	SNAP
MPOOLS	0	#AIR ATTEMPTS	245	235
COCBUFS	22	#AIR HITS	232	173
IOQ ENTRIES	3	#AIR TIMEOUTS	4	1
CFUS	37	#RAHD ATTEMPTS	18	101
GRAN PACK	36702	#RAHD STARTS	18	100
GRAN SYMB	3957	#RAHD USED	16	97
GRAN RAD	1272	#RAHD I/O WAIT	2	6
		#RAHD NOT USED	0	0
		#RAHD TIMEOUTS	2	1

CP-V D00 DUAL SIGMA 9 256K

11A  
20

# **CP-V D00**

## **THE CP-V ZOO**

- **FROG – FECF CONTROL**
- **LEMUR – LIBRARY MAINTENANCE**
- **LYNX – ON-LINE LOADER**
- **MOOSE – MULTIPROCESSING CONTROL**
- **OX – ON-LINE COMMAND FILES**
- **PIGEON – BROADCAST MESSAGES TO TERMINALS**
- **RATLER – CP-V FILE TRANSMISSION**